

IMPECTOR *fast 10*

Revolutionary Imaging Spectrograph for high speed applications; the ImSpector Fast10 is a high intensity imaging spectrograph which makes spectral imaging possible at hundreds and even up to 1500 images per second.

Visible near infrared wavelength range

IMPECTOR		FAST 10
Optical characteristics		
Spectral range	400 - 1000nm	
Spectral resolution *1	15nm (with 18µm slit)	
Image size	0.78 (spectral) x 14.3 (spatial) mm	
Spatial resolution *1	rms spot radius < 9µm	
Numerical aperture	F/3.2	
Slit width, default	18µm	
Slit length	14.3mm	
Optical input	Telecentric	
Efficiency	> 50%, independent of polarization	
Aberrations		
Vignetting	~0%	
Smile	< 4µm	
Keystone	< 4µm	
Mechanical characteristics		
Size, OEM	(W)55 x (H) x 60 x (L) 225mm	
Weight	1530g	
Body, OEM	Anonized aluminium	
Lens and camera mount	Standard C-mount adapter	
User adjustments	Image axis relative to detector rows, back focal length adjustable ±1mm	
Environmental characteristics		
Storage	-20 ... +80 °C	
Operating	+5 ... +40 °C, non-condensing	

ImSpector Fast10 imaging spectrograph provides:

- high light throughput
- superior image quality
- good spectral resolution of 15 nm
- full VNIR spectrum of 400 – 1000 nm over a narrow dimension, allowing short read out times
- maximum light intensity on the camera pixels, allowing short integration times
- high speed acquisition in many low cost industrial CCD and CMOS cameras

ImSpector Fast10 brings spectral imaging to high speed industrial applications, like on line color sorting, and fruit and vegetable inspection. It also takes airborne hyperspectral imaging to new speed level.

ImSpector Fast10 can also be supplied with multichannel fiber optics.

*1 System spectral and spatial resolutions also depend on the discrete imaging nature of detector and lens quality.



ImSpector Fast10, side view



ImSpector Fast10, front view

Options, fore optics

- Fore optics, Enhanced series: OLE18.5, OLE23 and OLE140 for 2/3" or larger detector

More information about fore optics can be found from the Hyperspectral fore lenses -data sheet.

Options, accessories

- Mechanical shutter
- Collection fiber optics
- Fiber optic diffuse irradiance sensor (FODIS) for light source monitoring

More information about fiber optics can be found from Multipoint spectrometers -data sheet.



ImSpector Fast10 combined with fore lens and camera

Applications

Skin scanning
 Industrial inspection
 Color sorting and matching
 Fruit and vegetable inspection
 Printing, wood, automotive
 Architecture
 Display and light source testing

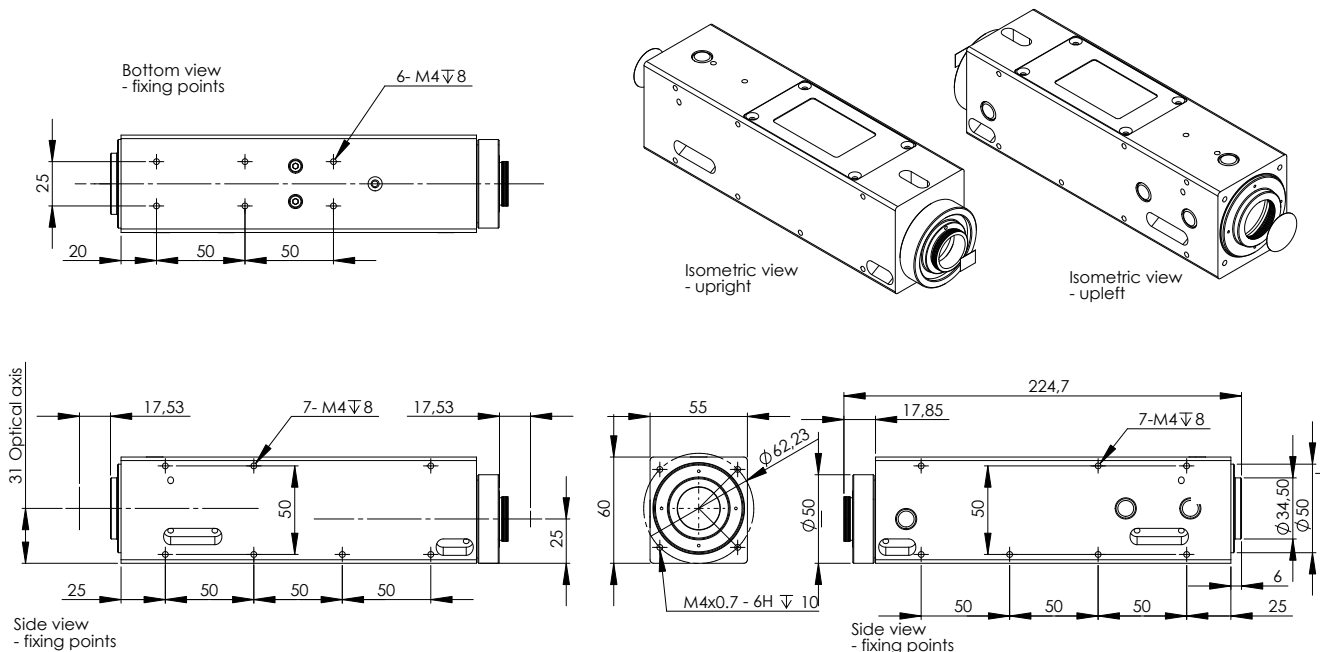

ImSpector Fast10 mechanical dimensions